

J. E. TANNER AND H. M. FOREHAND, "CRITICAL EXPERIMENTS FOR LARGE SCALE ENRICHED URANIUM SOLUTION HANDLING," PROCEEDINGS OF TOPICAL MEETING ON CRITICALITY SAFETY IN THE STORAGE FISSILE MATERIAL, SEPTEMBER 8-11, 1985, JACKSON, WYOMING (AMERICAN NUCLEAR SOCIETY REPORT ISBN:89448-119-3, 1985), PP. 65-79.

ISBN: 0-89448-119-3

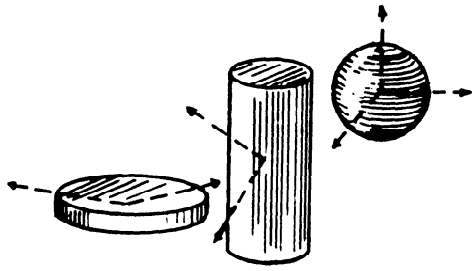

CRITICALITY SAFETY IN THE STORAGE OF FISSILE MATERIAL

PROCEEDINGS OF A TOPICAL MEETING

Jackson, Wyoming
September 8-11, 1985

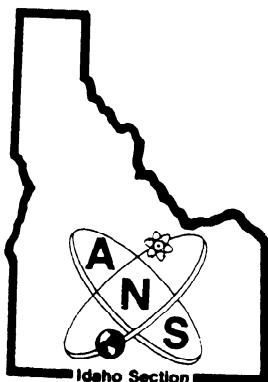

American Nuclear Society
Idaho Section
Nuclear Criticality Safety Division

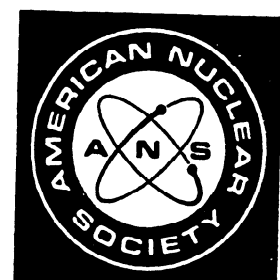

CRITICALITY SAFETY CONSIDERATIONS IN THE STORAGE OF NUCLEAR
MATERIAL THROUGHOUT THE FUEL CYCLE

September 9-12, 1985

Jackson, Wyoming

A Topical Meeting
Co-Sponsored by the
Idaho Section and the
Nuclear Criticality Safety Division
of the
American Nuclear Society

MEETING COMMITTEE

<u>General Chairman</u>	<u>Assistant General Chairman</u>	<u>Program Chairman</u>	
R. E. Wilson	F. S. Kirn	T. P. McLaughlin	
<u>Arrangements</u>	<u>Assistant Program Chairman</u>	<u>Publications</u>	
F. L. Dilorenzo	A. S. Garcia	C. H. Price	
<u>Finance</u>	<u>Registration</u>	<u>Tours</u>	<u>Public Relations</u>
E. Fast	A. S. Garcia	D. W. Knight	N. E. Cole

TECHNICAL PROGRAM COMMITTEE

T. P. McLaughlin	A. S. Garcia
G. Whan	F. M. Alcorn
G. H. Bidinger	R. D. Carter
C. M. Hooper	E. Walker
K. E. Elliott	M. C. Evans

Copyright © 1985
American Nuclear Society, Inc.
555 North Kensington Ave.
LaGrange Park, IL 60525

Printed in the United States of America
Date Published: August 1985

ISBN: 0-89448-119-3

ANS Order No. **700102**

CRITICAL EXPERIMENTS FOR LARGE SCALE ENRICHED URANIUM SOLUTION HANDLING

J. E. Tanner
Westinghouse Idaho Nuclear Company, Inc.
Idaho Falls, Idaho

H. M. Forehand
Los Alamos National Laboratory
Los Alamos, New Mexico

We have performed 17 critical experiments with a concentrated aqueous uranyl nitrate solution contained in an annular cylindrical tank, with annular cylindrical absorbers of stainless steel and/or polyethylene inside. k_{eff} calculated by KENO IV, employing 16-group Hansen-Roach cross sections¹, average 0.977. There is a variation of the calculational bias among the separate experiments, but it is too small to allow assigning it to specific components of the equipment. We are now performing critical experiments with a more concentrated uranyl nitrate solution in pairs of very squat cylindrical tanks with disc shaped absorbers and reflectors of carbon steel, stainless steel, nitronic-50, plain and borated polyethylene.

These experiments are in support of upgrading fuel reprocessing at the Idaho Chemical Processing Plant.

CRITICAL EXPERIMENTS FOR LARGE SCALE ENRICHED URANIUM SOLUTION HANDLING

INTRODUCTION

The Idaho Chemical Processing Plant is engaged in an extensive rebuilding program of its storage facilities for fissile or potentially fissile solutions. Plans include both slab-shaped and annular cylindrical storage tanks. Since we desire the maximum safe storage capacity in the volume available we need to be able to make accurate neutron multiplication calculations. For this reason the codes used must be validated against experiments containing the unique features of materials or dimensions involved in the plant designs^{2,3}.

Two previous sets of critical experiments^{4,5,6} employed annular tanks which were rather squat compared to the ones planned, and for which the annulus was not very thin compared to the overall diameter. We used equipment having dimensional ratios which more closely approximated those intended for construction here.

ANNULAR TANKS

Experiments

Equipment

The annular tank experiment was conducted in Kiva I at the Los Alamos Critical Assembly Facility. The Kiva is a remote assembly building with a main experimental room approximately 48 X 29 feet, concrete floor, 8-in. block walls, and a 4-in. reinforced concrete roof 26 feet high. The tank was elevated 62 inches above the floor using the Venus assembly stand, see Figure 1. The stand consisted of three 5-in. steel pipe legs on a 35-in. radius supporting an aluminum donut. The tank feet were bolted to the aluminum. The near walls were 77 and 81 inches from the tank outer surface. The other walls were in excess of 27 feet away. The roof was approximately 15 feet above the top of the tank.

The annular tank, Figures 1 and 2, was constructed with 304-L stainless steel. The radial walls were 1/8-in. thick and the top and bottom walls were 1/4-in. thick. The solution annulus averaged $3.51" \pm .03"$. The volumetric capacity of the tank was 335.6L from weight of water, or 333.3L from the dimensions. Wall deflection when fully loaded with water was less than 1/1000 of an inch.

Two nesting polyethylene rings, 0.776-in. and 1.390-in. thick at a density of .924g/cc, an annular water tank, and a 3/8-in.-thick 304-L liner were employed separately and in combination to provide internal moderation or absorption. The 304-L liner (when in place) resided between the polyethylene or water tank and the fissile solution in the annular tank. The water tank was constructed with 1/8-in. radial walls and 1/2-in. end plates of 304-L stainless steel. The water annulus was 1.75-in. thick.

To compensate for the poisoning effect of the internal materials, two nesting external shims of A36 steel (1/4- and 1/2-in. thick) were constructed. Only the 1/2-in. shim was employed, see Figure 3 for cross section view of all of these pieces in place, except the water tank, which replaces the polyethylene.

The fissile solution was uranyl nitrate with a concentration of 281g U-235/L and an enrichment of 93.07 weight percent. Details are given in the Appendix. The solution (300L) was stored in a 4 X 4 square pitch array of 6-in. borosilicate glass pipes. The pipes were on 18-in. centers and the central four positions were vacant. The annular tank surface was 72 inches from the surface of the near row of glass pipes, Figure 1.

A 1.94×10^7 n/s ^{252}Cf source was placed inside the annular tank at an elevation of 90.4 inches above the floor. Four polyethylene-moderated BF_3 detectors (in pairs at two elevations 109 and 83 inches above the floor) were used to measure count rate as a function of solution height. The source and detector positions were unchanged for the duration of the experiment. The two pairs of detectors were positioned approximately 180° apart. The low pair were 25-1/2 inches from the tank wall and the high pair were 24-3/4 inches from the annular tank wall.

Experimental Procedure

The approach-to-critical experiment was accomplished by increasing the k (the reproduction number) of the assembly in steps by adding solution and measuring the leakage multiplication, M , at each step, extrapolating to critical, and choosing the next step such that a safe and slow approach was maintained. The count rate, C , of a detector located near or in the assembly was taken as a measure of the neutron population. The multiplication is operationally defined as:

$$M = C/C_0$$

where C_0 = the unmultiplied source count rate. The unmultiplied source count rate was obtained with less than 17L of solution in the annular tank for all configurations. The overall shape of the inverse operational multiplication (count rate ratio) curve depends on source and detector location. However, as $k \rightarrow 1$, all possible $1/M$ trajectories approach zero at a common loading metric (solution height).

The data (solution height or volume and inverse count rate ratio (operational multiplication)) were fit (least-squares) to a quadratic to obtain the extrapolated critical point. A graph of the data for a typical experiment is presented in Figure 4.

CALCULATIONS

Equipment Modeling

Initial criticality calculations were performed using arbitrary fissile solutions to test the importance of small deviations of the equipment from regular geometry. The KENO IV code with 16-group Hansen-Roach cross sections¹ was employed.

In one series, the tank, with simplified versions of the view slit and bottom support plates, and including the floor and the two nearest walls, were modeled. Results are in Table I. The calculations show that the view slit structure, support plate, walls, and ceiling together add about 1% to k_{eff} . The portion caused by the view slit is within the calculational uncertainty, as was confirmed by a critical experiment (see below). Therefore, and to reduce the number of KENO boxes, the view slit was eliminated from the final model.

Separate simple models were constructed to determine the order of magnitude of the effects of the leg supports, of a slight gap where ends of the 3/8" stainless steel absorber were welded, and of a possible non-concentricity of the walls of the solution tank.

Calculations of an annular stainless steel absorber with various gap widths are presented in Table II. The actual effective gap due to thin welding where the sides of the plate join is estimated as less than 7/16". We see that there is no significant effect on neutron reactivity at as great as double this width.

The leg supports were conservatively modeled as 4 pieces of 0.18" steel flush against the bottom of the tank, evenly spaced around it, and subtending the same arc and length as the actual legs. Results are in Table III. The decrease in k with increasing reflection to twice the actual leg thickness is undoubtedly a statistical fluctuation superimposed on a negligible increase due to the reflection.

Calculated effects of a possible non-concentricity of the solution tank walls are presented in Table IV. The results fit an equation, $k = 1.012 + .0029 d^2$, where d is the separation of the two centers in cm. Any actual non-concentricity is certainly less than the 6mm needed to increase k by 0.001, therefore we ignore this possibility.

Several other apparatus imperfections were shown by experiment to be insignificant (see below) and were therefore omitted from the final model.

Experimental Results

Twelve experiments were performed with different configurations of the internal absorbers and external reflector. Three additional experiments tested the effect of the storage tubes and nearby equipment, so they could be deleted from the KENO model. These are listed in Table V.

The effect of the steel equipment underneath the tank was tested by adding an additional 40 pounds to the configuration of WAT 8. This decreased the crit-

ical height by 2.3cm (WAT 9). A recalculation with this height yielded a change in k_{eff} of 0.002, which is much less than statistical uncertainty.

The 4 rows of storage tubes for the uranium solutions were at distances of 6 to 10-1/2 feet from the annular tank (Figure 1). In one of the cases involving the most solution in storage (WAT 14), no significant change in critical solution height (in the annular tank) was found as the excess solution was placed in the closest row (WAT 15) or in the farthest row (WAT 16) from the annular tank.

The results for the various reflector and absorber combinations calculated by KENO are seen to be low (non-conservative) by 1-3%, with an overall average of 2.3%. The standard deviation of the 12 experiments, calculated as $\sqrt{\frac{1}{12} \sum (k_i - \bar{k})^2}$, is larger than the standard deviation for each k_i (calculated from 200 generations), suggesting that there are some real variations in method bias between the various configurations. However they are small enough that we have not been able to correlate them with the presence or absence of any particular absorber or reflector. Figure 5 shows that they do not correlate with critical solution height, suggesting that had the thinner reflector been used, and much greater critical heights obtained, the biases would have been roughly the same.

The 5 experiments with a polyethylene absorber average .979, which is not significantly different from the single experiment employing water.

Finally we note that by use of solution densities based on the International Critical Tables measurements⁷, we calculate a k_{eff} nearly 0.01 lower than with the ICPP - determined densities, showing the importance of accurate knowledge of this parameter.

We list in Table VI experiments performed at Oak Ridge National Laboratory⁴ and at the Rocky Flats⁵ Plant which have dimensions and materials most similar to the experiments performed by us. The k_{eff} we have calculated from both sets of experiments are higher than what we have calculated from our own, all using the same code and cross section set.

Variations in solution density measurements among the three different sets of experiments, if they are as great as the variations reported in the literature for uranium solutions, (see Appendix) could have caused a large amount of the discrepancies in k_{eff} ; but we have no information as to whether this is actually the case, nor any other suggestions for the cause of the disagreement among these critical experiments.

SLAB TANKS

Experiments

Equipment

We have constructed three squat cylindrical tanks of inner diameter 71cm and inner height 4, 9, and 10cm, respectively. The tanks were constructed of

1/8" 304L stainless steel. We fabricated or purchased disc-shaped pieces of polyethylene, borated polyethylene, stainless steel 304L, low carbon steel, and nitronic - 50, a high nickel steel, all of diameter 71cm, and of various thicknesses, to use as absorbers between the tanks, or as reflectors on opposite sides of a tank or pair of tanks.

Experimental Procedure

The experiments are being performed on the LASL PLANET machine. The tank, absorbers, and reflectors lie flat in two stacks which are brought together by an upward motion of the lower one to achieve criticality. Dimensions are designed so that criticality will be attained with the stacks as close together as possible. In cases where criticality is not reached with the stacks touching, the experiment is repeated with thin reflector sheets at the far ends of the two stacks.

CALCULATIONS

Equipment Modeling

The KENO model of the PLANET apparatus included the support platform, a 6" tall or 12" tall honeycomb, a 1/32" diaphragm originally intended to support the upper stack, and the outer steel ring on which the diaphragm lies, and on which the upper solution tank rests directly by means of projecting supports in the final design. The honeycomb is a grid of 1/8" aluminum plates on edge, and spaced 6" apart. For ease in calculation it was conservatively modeled as homogenized with its enclosed air spaces.

The importance of the various parts was tested by calculations where combinations of them were substituted with air. Results are in Table VII.

It appears that the support ring by itself, and maybe even the 6" honeycomb, do not add a significant amount of reflection. Adding the support platform at that distance contributes 3% - 4% to k_{eff} . Removing the platform to 12" removes about half of this. All of these components were kept in the KENO model used to calculate the actual critical experiments.

CONCLUSIONS

We have performed a set of critical experiments with concentrated highly enriched uranium in aqueous solution in an annular cylindrical tank. KENO IV calculations at the critical heights average .977, a non-conservative bias of 2.3%. We are not able to show what experimental or calculational factors are responsible for this bias. Critical experiments employing uranium solution in parallel slab tanks are in progress.

REFERENCES

1. L. M. Petrie and N. F. Cross, "KENO IV, An Improved Monte Carlo Criticality Program," ORNL-4938, Oak Ridge National Laboratory, November 1975.
2. DOE Manual 5480.1, Chapter V.
3. ANS National Standard 8.1.
4. J. K. Fox, L. W. Gilley, and D. Callihan, "Critical Mass Studies, Part IX, Aqueous U-235 Solutions," ORNL-2367, Oak Ridge National Laboratory, March 1958. See Chapter III.
5. Robert E. Rothe, "Criticality Safety of an Annular Tank for Fissile Solution," Trans. Am. Nucl. Soc. 39, 525 (1981).
6. J. S. Pearson, "Calculational Results Compared to Benchmark Critical Experiments on Annular Tanks," presented at the annual meeting of the American Nuclear Society, June 13, 1983, Detroit, Michigan.
7. International Critical Tables Volume III, p. 71.
8. J. A. Johnson and K. A. Kraus, J. Am. Chem. Soc. 75, 4594 (1953).

Table I. Effects Of Imperfections In Full Annular Tank Experimental Model.
600 Neutrons/Generation. $\sigma = + .003$

C o m p o n e n t s P r e s e n t				k_{eff}	Neutron Histories
Internal 3/8" Steel and Poly- ethylene	Viewslit Structure	Aluminum Support Plate	Two Walls and Floor		
---	---	---	---	1.001	120,000
---	X	X	X	1.009	120,000
X	---	---	---	.879	95,000
X	---	---	X	.883	118,000
X	---	X	X	.883	74,000
X	X	X	X	.887	88,000

Table II. Effect Of Gap In Absorbing Steel Annulus. Actual Gap < 7/16".

Gap	0	7/16"	7/8"
k_{eff}	1.006	1.008	1.009
	$\pm .003$	$\pm .003$	$\pm .003$
Neutron Histories	89,000	87,000	92,000

Table III. Effect Of Solution Tank Leg Supports. Four Legs Subtending The Same Arc And Length As The Actual Three Legs. Actual Thickness is 1/8".

Leg Thickness	0	.177"	1/4"
k_{eff}	1.015	1.013	1.011
	$\pm .003$	$\pm .003$	$\pm .003$
Neutron Histories	94,000	95,000	95,000

Table IV. Calculated k_{eff} In Cylindrical Annulus With Non-Concentric Inner•Outer Boundaries. Solution Annular Thickness 8.92cm. Steel Wall Thickness .3cm. Outer Diameter 76.2cm. 273g U-235/L.

Distance Between Centers Of Inner•Outer Walls, cm	k_{eff}
0	1.014
2	1.021
4	1.059

Table V. Results Of LASL Annular Tank Experiments

	Inner Polyethylene Absorber (cm)	Inner Steel Absorber (in)	Exterior Reflector (in)	Critical Solution Height (cm)	KENO, k_{eff} With 200 Generations Of 600 Neutrons Each. $\sigma = .003$	
					@ $d = 1.418$ I.C.T.	@ $d = 1.433$ CPP
WAT 1				129.8	.973	.979
WAT 5				128.3		
WAT 11			1/2	87.3		.977
WAT 12	1.97		1/2	68.4		.975
WAT 14	3.53		1/2	76.4		.989
WAT 15 ^a	3.53		1/2	76.1		.984
WAT 16 ^a	3.53		1/2	76.2		
WAT 13	5.50		1/2	92.3	.973	.985
WAT 2		3/8		124.9		.974
WAT 7		3/8	1/2	80.2		.973
WAT 8	1.97	3/8	1/2	91.4		.975
WAT 9 ^b	1.97	3/8	1/2	89.1		.973
WAT 6	3.53	3/8	1/2	123.4		.976
WAT 17	empty tank		1/2	81.1		.975
WAT 19	empty tank	3/8	1/2	74.3	.966	.973
WAT 18	full tank		1/2	99.3		.981
						<u>.977₃</u> $\sigma = .005$

^aIn all other experiments the reserve solution was equally divided between the storage tubes. In experiments 15 and 16 all of the reserve solution was in the closest or the farthest row of tubes, respectively. However only the change in critical height was modeled.

^b40 lb of steel was placed under the uranium tank, but not modeled. The change in critical height was modeled.

Table VI. Important Experimental Parameters For Critical Experiments At Oak Ridge (2) and Rocky Flats (3). Dimensions in cm.

		Solution Annulus					g U-235/L	Core		k _{eff}	
		ID	OD	Height	H/ID	ID/OD		ID	Material		
A. Oak Ridge	1.	15.2	25.4	64.1	4.2	.60	331	0	Water	1.006	
	2.	15.2	25.4	76.8	5.1	.60	331	-	Air	1.028	
	80 ± 5 Generations,	3.	25.4	38.1	41.6	1.6	.67	342	0	Water	1.021
	300 Neutrons, Each	4.	38.1	50.8	44.3	1.2	.75	342	0	Water AVERAGE	1.013 1.017
B. Rocky Flats	5.	58.8	90.0	39.7	.7	.65	333	-	Air	.969	
	6.	58.8	90.0	46.0	.8	.65	333	0	1.6mm Cd + Concrete	1.020	
	7.	58.8	90.0	35.7	.6	.65	333	0	Concrete	.997	
	8.	58.8	90.0	37.4	.6	.65	333	41.5	Concrete	1.000	
	100 Generations	9.	58.8	90.0	44.5	.8	.65	333	41.5	Concrete, 1.6% B	.989
	1000 Neutrons, Each	10.	58.8	90.0	47.1	.8	.65	333	21.0	Concrete, 1.6% B	.986
	11.	58.8	90.0	48.5	.8	.65	333	41.5	Concrete, 2.7% B	.984	
	12.	58.8	90.0	43.5	.7	.65	333	0	Water	.974	
	13.	58.8	78.1	93.5	1.6	.75	333	-	Air	.976	
	14.	58.8	78.1	106.5	1.8	.75	333	0	Concrete	1.022	
	15.	58.8	78.1	79.5	1.4	.75	333	41.5	Concrete AVERAGE	1.003 .993	

Average Calculated at Rocky Flats
(Private communication from
J. S. Pearson of Rocky Flats Plant) .987

Table VII. KENO Calculations Of The Importance Of Components Of PLANET Apparatus 29,400 Neutron Histories, $\sigma = 0.006$.

Components Present

Two 7.2cm Solution Tanks, 1/32" Diaphragm	Ring	Honeycomb	Platform	k_{eff}
X				.947, .959
X	X			.946
X	X	6"		.959
X	X	6"	X	.987
X	X	12"	X	.970

Figure 1. Annular Tank on Venus Assembly Stand (left). Glass Solution Storage Tubes (right).

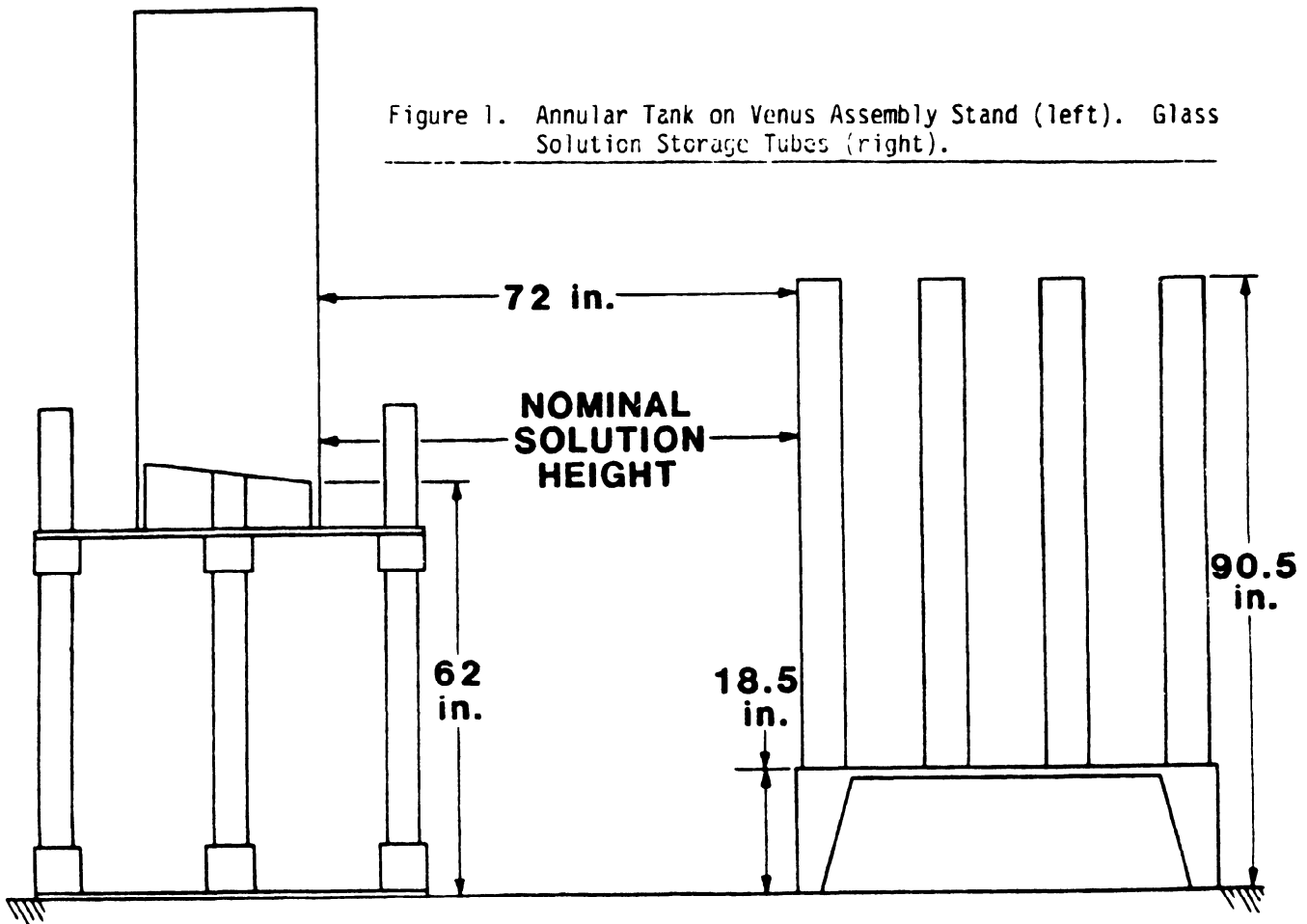

Los Alamos

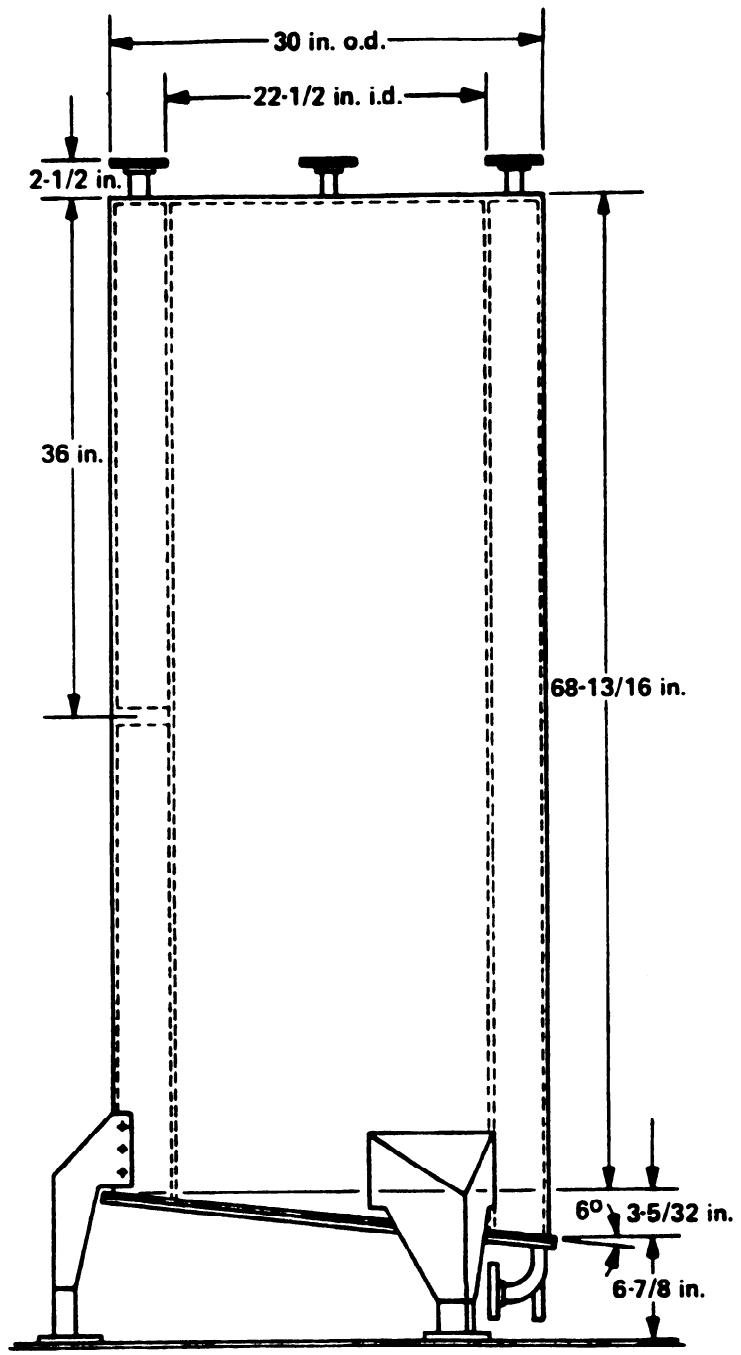

Figure 2. Vertical Cross Section of Annular Tank.

Los Alamos

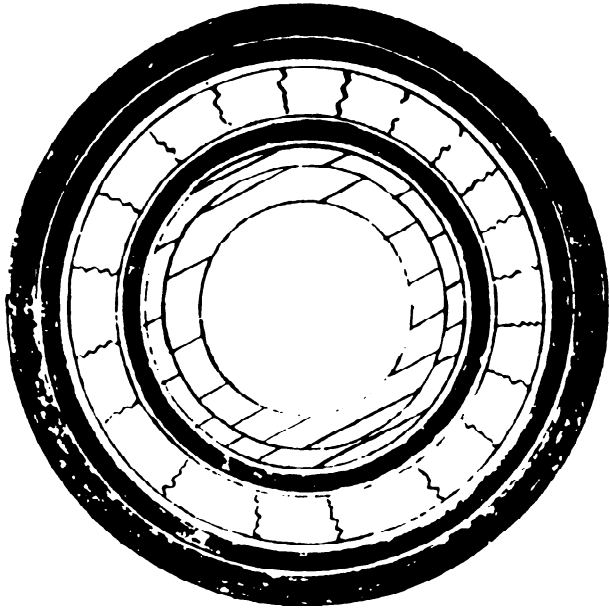

Figure 3. Horizontal Cross Section of Tank with All Absorbers and Reflectors in Place.

- ~~ = solution
- / = borated polyethylene
- = steel

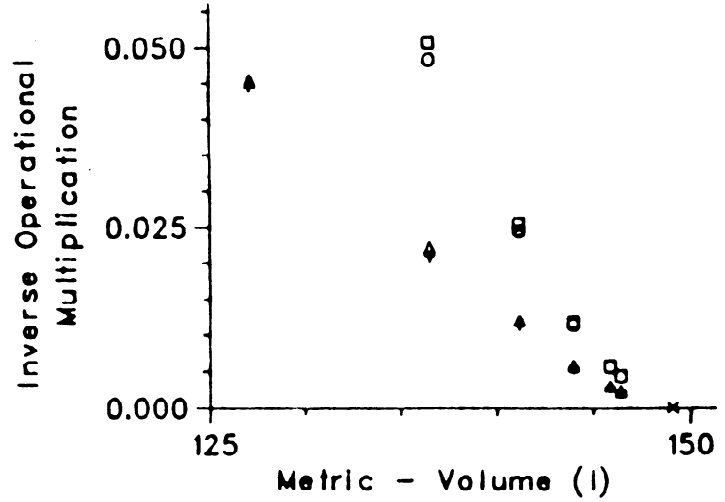

Figure 4. Approach to Critical for WAT 7.

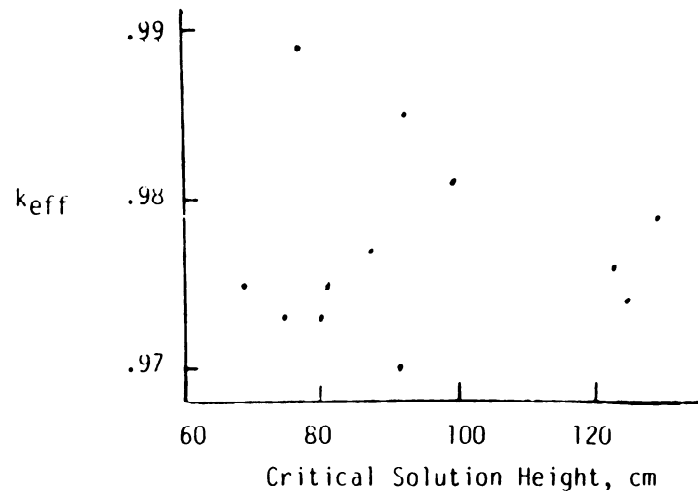

Figure 5. Calculated k_{eff} Versus Experimental Critical Height.

APPENDIX

SOLUTION COMPOSITION

The solution compositions as determined at the ICPP are given in the first column of each experiment in Table A1. These lead directly to the atomic densities by standard formulas. We corrected the measured density to d_{-4}^{17} by means of handbook values of the density of water, and the temperature correction for uranium solutions:

$$d_t - d_{25} = (.000145 - .0005d_{25}) (t - 25) = .005 \text{ (Ref. 1).}$$

Probably the greatest uncertainty in atomic densities is caused by uncertainty in the measured density. The effects on both fissile and moderator concentration are in the same direction of k , rather than in compensating directions, as when one considers concentration changes near a reactivity maximum. Literature values of densities of aqueous uranyl nitrate solutions vary significantly (1 - 5). The ICPP value is about the average of what would be calculated from these references. We will compare these using the annular tank solution as an example. First we "correct" the ICPP value for the trace nitrates by means of $d_{\text{corrected}} = d_{\text{measured}} - \sum a_i c_i$, where c_i are the molar concentrations, and $a = .052, .15,$ and $.18$ for the nitrates of Na, Al, and Fe, respectively (1, 6), and obtain $d_{-4}^{25} = 1.426$. For comparison, we curve-fitted data from the other references, and obtained: 1.409 (Reference 2), 1.421 (Reference 3), 1.422 (Reference 1), 1.431 (Reference 4) and 1.436 (Reference 5) for the density of a solution of this composition.

REFERENCES

1. Criticality Handbook, ARH-600, Vol. I, ed. R. D. Carter, G. R. Kiel, and K. R. Ridgway, Atlantic Richfield Hanford Co., May 1969, Section II, page D. 4-1.
2. International Critical Tables, III, page 71.
3. W. Davis, P. S. Lawson, H. J. de Bruin, and J. Mrochek, J. Phys. Chem., **69**, 1904 (1965).
4. H. H. Ph. Moeken, Anal. Chim. Acta, **44**, 225 (1969).
5. J. L. Botts, R. J. Raridon, and D. A. Costanzo, "Density, Acidity, and Conductivity Measurements of Uranyl Nitrate/Nitric Acid Solutions," ORNL/TM-6491, Oak Ridge National Laboratory, October 1978.
6. Handbook of Chemistry and Physics 60th ed., Chemical Rubber Co. Press (1979), page D-247ff.

Table AI. Solution Compositions

		Annular Experiments			Slab Experiments	
		Isotope wt%	Atomic Density @ d17 = 1.433 4	Atomic Density @ d17 = 1.418 4	Isotope wt%	Atomic Density @ d17 = 1.553 4
U-234	92400	.86	7.E-6	7.E-6	.84	8.7-6
U-235	9250X*	93.05	7.24E-4	7.16E-4	93.11	9.55-4
U-236	92600	.28	2.E-6	2.E-6	.28	2.8-6
U-238	92853	5.81	4.4E-5	4.4E-5	5.77	5.8-5
Total U		21.17 wt% μg/gU			25.79 wt% μg/gU	
Al	13100	732	4.9E-6	4.9E-6	1090	1.2-5
Na	11100	649	5.1E-6	5.1E-6	610	7.7-6
Fe	26100	293	9.E-7	9.E-7	250	1.3-6
Si	14100	126	8.E-7	8.E-7		
Excess H+ ²⁵ d ₂₀	1102	.56N 1.431 g/cc	3.4E-4	3.4E-4	.32N 1.551 g/cc	1.9-4
Nitrate N	7100		1.92E-3	1.91E-3		2.29-3
Nitrate & Uranyl O	8100		7.31E-3	7.24E-3		8.91-3
H ₂ O	502		.893	.883		.864

*X = 9 and 8 for annular and slab solutions, respectively.